

MX36-GCB Series
HIGH-AMP CIRCUIT BREAKER – PANEL MOUNT



PELCO COMPONENT TECHNOLOGIES • 855 227 3526



MX36-GCB Series offers three types of panel mount high-amp circuit breakers. All are waterproof and meet IP67 standards.

MX36-GCB (shown): Type III, manual reset with switch, available with current ratings from 25–180Amps.

EXAMPLES OF MX36-GCB SERIES APPLICATIONS include:

- Auxiliary and accessory circuits
 - Trucks and Buses
 - Battery Chargers
 - Recreational Vehicles
 - DC Audio Systems
- ...and many more

MX36-GCB-A: Type III, manual reset, available with current ratings from 25–180Amps.

MX36-GCB-B: Type I, automatic reset, available with current ratings from 25–180Amps.

SPECIFICATIONS

■ **Trip Time vs. Overload at 25°C**

- At 100% of rated current: no trip
- At 135% of rated current: trip within 30 minutes
- At 200% of rated current: trip within 12-45 seconds
- At 300% of rated current: trip within 3.5–15 seconds

■ **Current and Voltage Ratings**

25A–180A, 48VDC maximum

■ **Interrupt Capacity**

3000A at 30VDC

■ **Operating Temperature**

-32°C to 82°C

■ **Storage Temperature**

-34°C to 149°C

■ **Housing**

Thermoset plastic, UL rated 94VO

■ **Standard Testing**

SAE J1625; SAE J1171
 (ignition protected);
 IP67 (waterproof)

■ **Approvals**

UL1500, RoHS compliant

TEMPERATURE DERATING CURVE

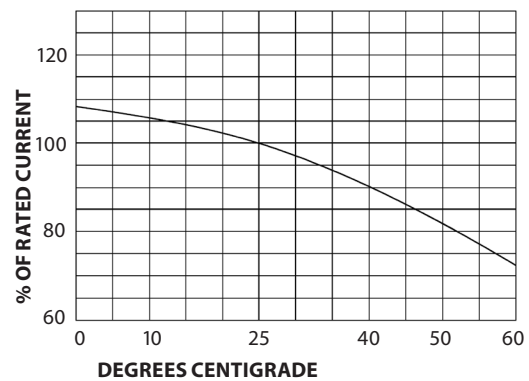

TRIP TIME CURVE

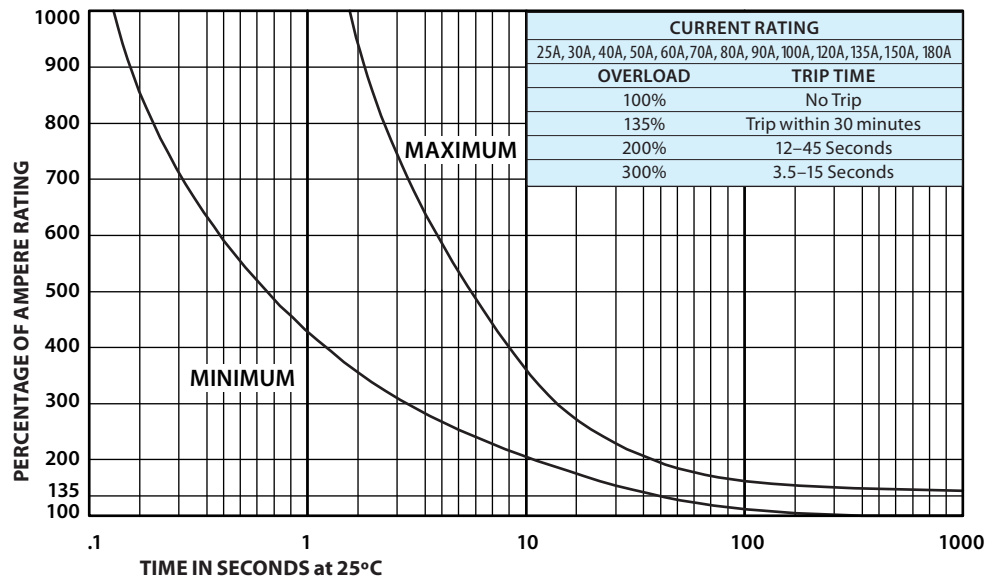

DIMENSIONS in mm

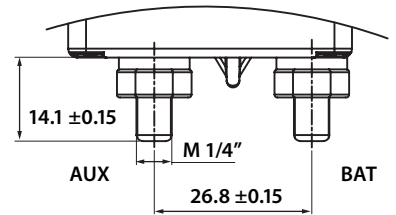
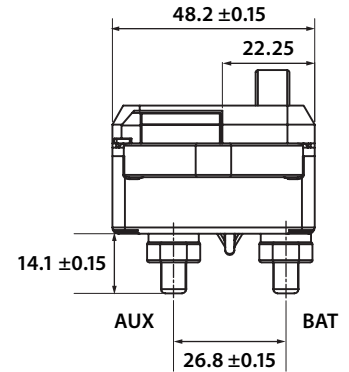
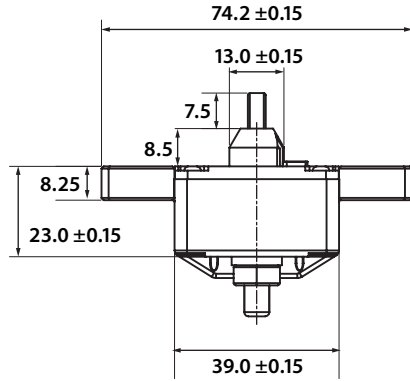
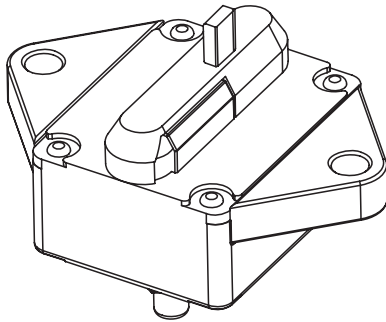

Stud size 1/4", 28 threads per inch
Use ring terminals

OPTIONS SELECTION

Series	Amps select by number	Amps select by number
MX36-GCB Manual Switch Reset		
High-Amp Circuit Breakers	25 25A	90 90A
	30 30A	100 100A
	40 40A	120 120A
	50 50A	135 135A
	60 60A	150 150A
	70 70A	180 180A
	80 80A	



Series	Amps select by number	Amps select by number
MX36-GCB-A Manual Reset		
High-Amp Circuit Breakers	25 25A	90 90A
	30 30A	100 100A
	40 40A	120 120A
	50 50A	135 135A
	60 60A	150 150A
	70 70A	180 180A
	80 80A	



Example: **MX36 GCB A 70**

MX36, Panel mount, Manual reset, 70 Amps

Series	Amps select by number	Amps select by number
MX36-GCB-B Automatic Reset		
High-Amp Circuit Breakers	25 25A	90 90A
	30 30A	100 100A
	40 40A	120 120A
	50 50A	135 135A
	60 60A	150 150A
	70 70A	180 180A
	80 80A	



ACCESSORY

MX36-GCB/C

Cover Panel Mount
for MX36-GCB,
MX36-GCB-A,
MX36-GCB-B

